

A APPENDIX

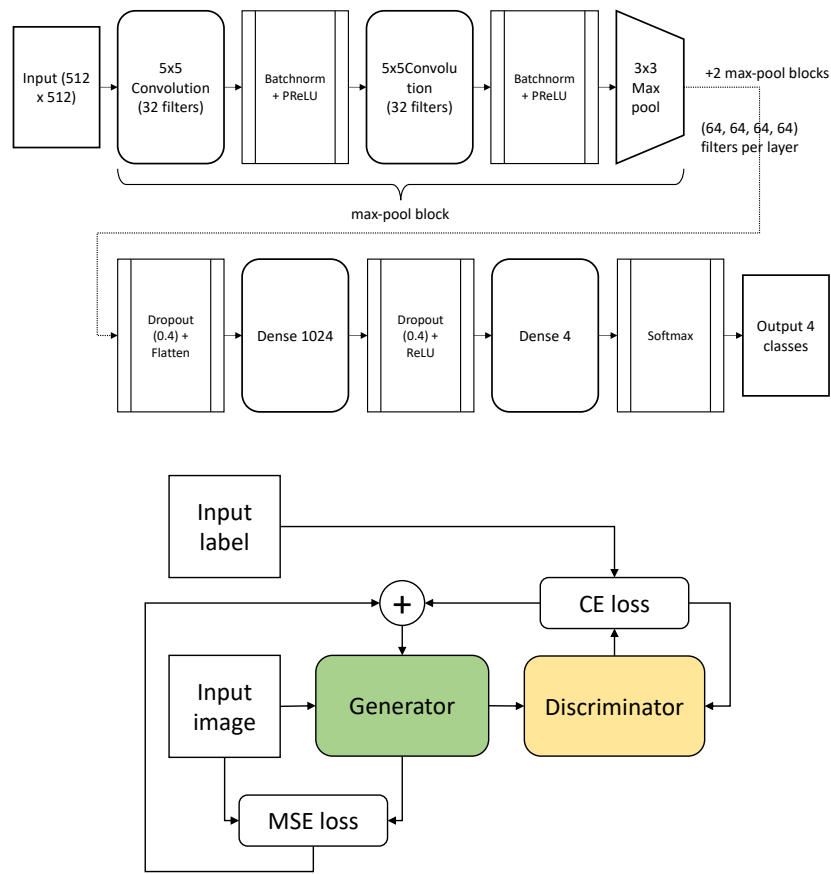

Figure 4: Extended Data Figure 1: Model Architecture. Top: layerwise architecture of our classifier, architecture initially from DeepDicomSort. Bottom: Depiction of the general structure for our GAN architecture.

702
703
704
705
706
707
708
709
710
711
712
713
714
715
716
717
718
719
720
721
722
723
724
725
726
727
728
729
730
731
732
733
734
735
736
737
738
739
740
741
742
743
744
745
746
747
748
749
750
751
752
753
754
755

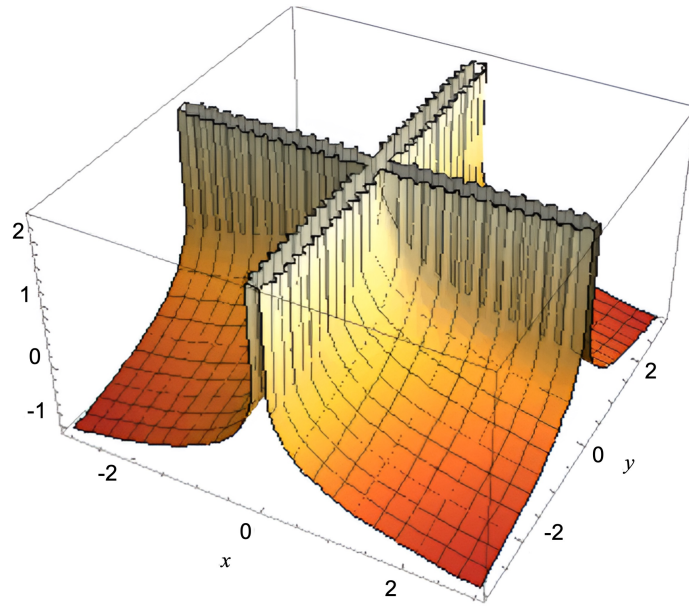

Figure 5: Extended Data Figure 2: Two-class example of our inverse cross-entropy loss structure.

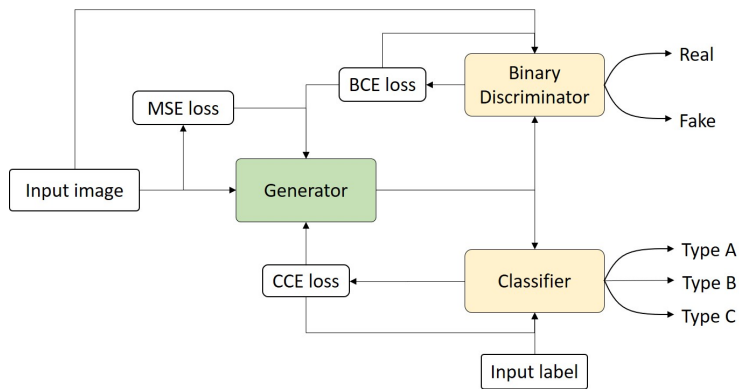

Figure 6: Extended Data Figure 3: Three-player architecture schematic