ComBack: A Versatile Dataset for Enhancing Compiler Backend Development Efficiency

Ming Zhong^{1,2}, Fang Lyu^{1*}, Lulin Wang¹, Hongna Geng^{1,2}, Lei Qiu^{1,2}
Huimin Cui^{1,2*}, Xiaobing Feng^{1,2}

¹ SKLP, Institute of Computing Technology, CAS, Beijing, China ² UCAS, Beijing, China

{zhongming21s, flv, wanglulin, genghongna, qiulei21b, cuihm, fxb}@ict.ac.cn

Abstract

Compiler backends are tasked with generating executable machine code for processors. With the proliferation of diverse processors, it is imperative for programmers to tailor specific compiler backends to accommodate each one. Meanwhile, compiler backend development is a laborious and time-consuming task, lacking effective automation methods. Although language models have demonstrated strong abilities in code related tasks, the lack of appropriate datasets for compiler backend development limits the application of language models in this field.

In this paper, we introduce ComBack, the first public dataset designed for improving compiler backend development capabilities of language models. ComBack includes 178 backends for mainstream compilers and three tasks including statement-level completion, next-statement suggestion and code generation, representing common development scenarios. We conducted experiments by fine-tuning six pre-trained language models with ComBack, demonstrating its effectiveness in enhancing model accuracy across the three tasks. We further evaluated the top-performing model (CodeT5+) across the three tasks for new targets, comparing its accuracy with conventional methods (Fork-Flow), ChatGPT-3.5-Turbo, and Code-LLaMA-34B-Instruct. Remarkably, fine-tuned CodeT5+ with only 220M parameters on ComBack outperformed Fork-Flow methods significantly and surpassed ChatGPT and Code-LLaMA, suggesting potential efficiency improvements in compiler development. ComBack is available at <https://huggingface.co/datasets/docz-ict/ComBack>.

1 Introduction

A compiler is a fundamental computer software which translates source code from high-level programming language into low-level machine code, *e.g.*, assembly code, for target machines (referred to as "**target**" for simplicity).

As shown in Fig. 1, mainstream compilers like GCC [18] and LLVM [30] are divided into three parts: frontend, middle-end and backend. Specifically, the frontend related to programming languages, while the middle-end comprises of target-independent optimizations, and backend converts intermediate representation produced by the middle-end into machine code for various targets. The flourishing development of new processors nowadays demands continuous development for backends.

Compiler backend development necessitates a profound understanding of the target characteristics and the compiler infrastructure [19]. Thus, it entails prolonged development cycles and substantial manual

*Corresponding author

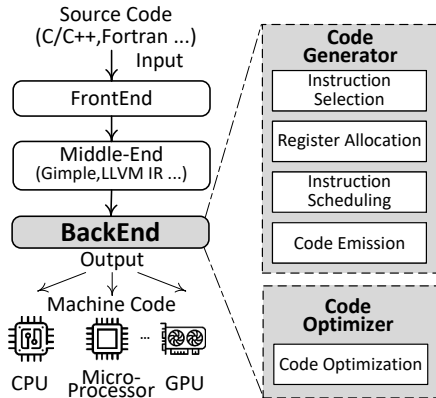

Figure 1: Compiler backend structure.

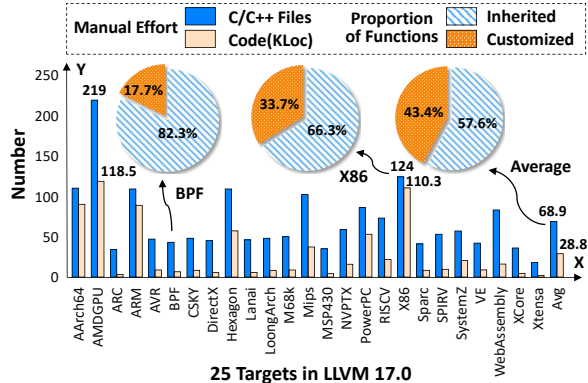

Figure 2: Heavy manual efforts in backends development for 25 targets in LLVM 17.0.1.

efforts. Data depicted in Fig. 2 underscores the magnitude of manual efforts and the distribution of functions across the development of compiler backends for 25 targets in LLVM 17.0.1 (latest released version). For instance, AMDGPU comprises 219 C++/C files, totaling 118.5 KLoC (Line of Code), while X86 comprises 124 files with 110.3 KLoC. On average, a LLVM backend in LLVM 17.0.1 consists of 68.9 files, encompassing 28.8 KLoC, indicating considerable manual efforts.

The emergence of AI has spurred considerable interest in leveraging its techniques for code-related tasks, such as code completion and generation [34, 14, 22, 50, 49, 21, 23, 45, 56]. Models like Code-LLaMA [45] have shown promise in significantly reducing the burden on programmers by being pre-trained on extensive code datasets. However, their efficacy in tasks concerning compiler backends, as evidenced by experimental findings in Sec. 4.3, remains limited, indicating ample room for enhancement. Moreover, the compiler community currently lacks a publicly available large-scale backend dataset, which could enhance the efficiency of backend development across diverse targets.

In this paper, we present ComBack, which is the first public dataset leading to a promising future for the application of language models for backend development. ComBack comprises 178 backends for mainstream compilers (77 from GCC and 101 from LLVM), sourced from open-source GitHub repositories. We also design three tasks to evaluate the performance of language models based on ComBack for three prevalent scenarios encountered in backend development, including 1) Statement-Level Completion, 2) Next-Statement Suggestion, 3) Code Generation.

In the experiment, we selected 6 representative open-source language models [50, 23, 14, 49, 22, 7] and fine-tuned them with ComBack. The results indicate that ComBack effectively improves the accuracy of 6 language models across 3 tasks. Furthermore, we conducted research on executing three code tasks for three new targets within GCC and LLVM. Additionally, experimental findings show that fine-tuning a model with just 220M parameters based on ComBack significantly boosts programmers' efficiency compared to Fork-Flow, ChatGPT and Code-LLaMA, demonstrating the value of ComBack in enhancing the language model's performance with compiler backend development.

2 Background: Conventional Backend Development Process

To develop a compiler backend for a new target, programmers are required to provide specific implementations for a series of compiler infrastructure provided function interfaces based on target-dependent information and characteristics, including instruction sets, registers, byte order, and similar attributes. Specifically, functions within a backend can be divided into two categories:

Inherited Functions. This category includes compiler infrastructure function interfaces that carry out specific tasks in the backend process. Programmers must inherit these interfaces and provide implementations tailored to each target. For instance, the "getReloctype" function in LLVM maps relocation variants and immediate values in instruction sets. Differences in this function across targets mainly involve target-specific relocation variants and immediate values. It's important to note that programmers need not to implement all provided interfaces but only a subset relevant to the target, resulting in variations in the implemented inherited functions across different targets.

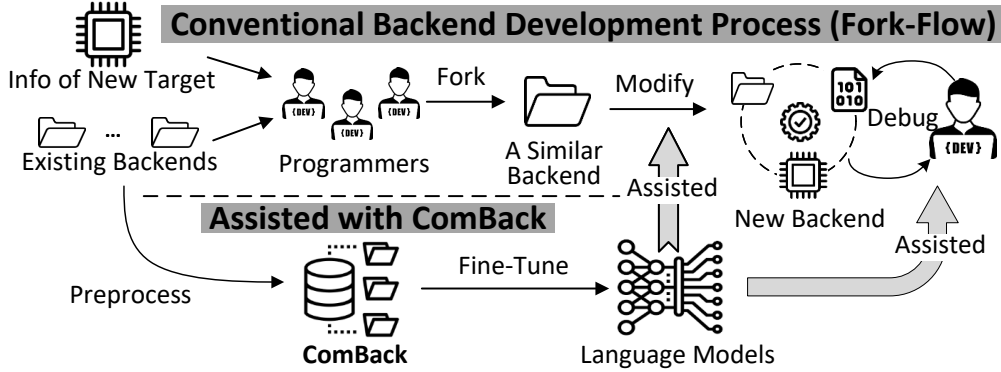

Figure 3: Conventional backend development process and assisted process with ComBack.

Customized Functions. This category includes specialized functions designed specifically for certain targets. For example, the "isImm24bit" function in ARM target checks if the encoding length of an immediate value is 24 bits, unique to ARM and not found in other targets.

Fig. 2 shows the proportion of two types of functions in LLVM 17.0.1. In BPF, 82.3% of functions, and in X86, 66.3%, are inherited from LLVM interfaces. On average across all 25 targets, inherited functions account for 57.6%. This prevalence highlights the significant presence of inherited functions across various targets, indicating a notable commonality among them.

Fig. 3 depicts the conventional backend development process (**Fork-Flow**) [43, 32], where programmers must acquire knowledge of the unique characteristics of a new target, such as instruction formats and target-specific flags. They then fork an existing backend that shares similarities (e.g., both being CPU or GPU) and make modifications based on this knowledge to create a tailored backend for the new target. Despite its steep learning curve, similarities among backends of the same type result in redundant development efforts, causing inefficiencies in manual work.

To mitigate this challenge, we propose ComBack, which can be utilized to fine-tune models and facilitate fine-tuned models to assist programmers with backend development, as shown in Fig. 3, thereby reducing redundant efforts and enhancing efficiency.

3 ComBack: A Dataset for Compiler Backend Development

3.1 Overview of ComBack

To the best of our knowledge, ComBack is the first public dataset for compiler backend development. Notably, it comprises three features as outlined below:

- (1) **Large-Scale.** ComBack is sourced from 317 GitHub repositories and the official websites of GCC [20] and LLVM [33], covering versions 3.0 to 13.0 for GCC and 2.0.1 to 17.0.1 for LLVM. It includes 43,299 functions and 883.7 KLoC (Kilo lines of code) for GCC, and 138,940 functions and 4,847.5 KLoC for LLVM, shown in Table 1. Its large scale enhances model performance on common backends and facilitates generalization to less common ones.
- (2) **Multi-Target.** Mainstream compiler infrastructure now supports multiple backends for diverse targets, requiring ComBack to be inclusive of such diversity. As indicated in Table 1, there are a total of 77 targets for GCC backends and 101 for LLVM backends in ComBack. These targets cover various types including CPUs, MPUs (Micro-Processors), GPUs, etc. Among them, CPUs and MPUs are more abundant due to their wide applicability across various scenarios. In contrast, other types of processors such as GPUs and DSPs are fewer as they are usually designed for specific tasks, such as GPUs for deep learning workloads and parallel data computation. Leveraging commonalities among these targets, as discussed in Sec. 1, enables models to learn cross-target patterns, facilitating advanced research among various backends. For detailed target information, refer to Appendix A.

Table 1: Data statistics about targets and code in ComBack.

(a) GCC				(b) LLVM			
Type	Target	Function	KLoC	Type	Target	Function	KLoC
CPU	30	35,147	647.2	CPU	43	84,914	3,450.4
MPU	33	6,010	183.9	MPU	30	11,311	173.0
GPU	2	457	11.2	GPU	5	22,591	768.3
VLIW	5	959	25.4	VLIW	4	2,048	24.3
DSP	3	399	9.6	DSP	7	9,646	263.2
Virtual	4	327	6.5	Virtual	12	8,430	168.3
Sum	77	43,299	883.7	Sum	101	138,940	4,847.5

- (3) **Versatility.** To tackle real-world challenges in compiler backend development, like code completion, ComBack focuses on enhancing model versatility. It covers three tasks: 1) Statement-Level Completion; 2) Next-Statement Suggestion; 3) Code Generation, aiding programmers in backend modification and customization. By analyzing diverse target backends, models can better assist with code completion and generation for both existing and new backends. This adaptable approach reduces programming workload, enabling ComBack to handle various scenarios.

3.2 Data Collection and Pre-processing

The collection and pre-processing of data in ComBack adhere to the following steps:

1. **Code Collection.** We crawled GitHub using "GCC/LLVM+Backend" as keywords, filtering out incomplete repositories. This yielded 21 GCC repositories and 296 LLVM repositories. We also collected source code versions 3.0 to 13.0 from the official GCC website [20], and versions 2.0.1 to 17.0.1 from the official LLVM website [33]. The backend code from multiple repositories was aggregated and reorganized by targets to create the raw code data.
2. **Function Description Collection.** We collected function descriptions from two sources. Firstly, we extracted descriptions directly from comments within the source code associated with each function. Additionally, for LLVM, we obtained function descriptions from its official Doxygen website [31] using crawling techniques to analyze them further.
3. **Code Extraction.** We started by removing duplicate files and comments from the source code for each target to minimize their influence on fine-tuning. Then, we used the tree-sitter tool [47] to extract functions from the code after comment removal. Each line ending with ";", ":", "{", or "}" was partitioned into a single statement, allowing us to obtain all functions within the backend source code along with their internal statements.
4. **Target-Specific Value Extraction.** Backend code, unlike basic C/C++ programs, prominently includes target-specific values comprising information and characteristics of the instruction set architecture (ISA) of the corresponding target. Fig. 4(a)-(c) illustrates three typical target-specific values: instruction encodings (Fig. 4(c)), size (Fig. 4(c)), immediate values (Fig. 4(b)), and target-specific flags (Fig. 4(a)).

Observations indicate that target-specific values can be categorized into 3 types: (1) numerical values (Fig. 4(b) and (c)); (2) strings in double quotation marks (Fig. 4(c)); (3) enumeration variable values with the target’s name prefix (Fig. 4(a)). However, some enumeration values may start with the target name abbreviation, like "PPC" for "PowerPC".

We use a script to automatically filter out target-specific values based on these patterns, including enumeration values starting with abbreviations, like "PPC". Following the approach used in CodeXGlue [34], we replace target-specific values in the code with intermediate representations: "<ISA_LIT>" for enumeration variables, "<NUM_LIT>" for numerical values, and "<STR_LIT>" for strings. Moreover, we store each target-specific value corresponding to these intermediate representations. All target abbreviations are listed in Appendix B.

<pre> case RISCVII::MO_LO: Kind = RISCVMCEExpr::VK_RISCV_LO; </pre>	<pre> ... return isImm(16, 31); </pre>	<pre> ... OS.write("\\0\\0\\x40\\x03", 4); </pre>
<pre> case CSKYII::MO_GOT32: Kind = CSKYMCEExpr::VK_CSKY_GOT; </pre>	<pre> ... return isImm(-8, 7); </pre>	<pre> ... OS.write("\\x20", 1); </pre>

(a) Target-Specific Flag and VariantKind (b) Immediate Value (c) Instruction Encoding and Size

Figure 4: Examples of target-specific values in GCC and LLVM.

```

Inputs: ... adjustReg(DL, SPReg, FPReg, -StackSize+RVFI->getVarArgsSaveSize(), _____)
Ground Truth: MachineInstr::FrameDestroy);

```

(a) Statement-Level Completion

```

Inputs: ... maxCallFrameSize = (maxCallFrameSize + AlignMask) & ~AlignMask;
Ground Truth: MFI -> setMaxCallFrameSize(maxCallFrameSize);

```

(b) Next-Statement Suggestion

```

Inputs:
getPointerRegClass: Returns a TargetRegisterClass used for pointer values.
Target-Specific Value: Sparc, SP::I64RegsRegClass, SP::IntRegsRegClass.
Ground Truth:
TargetRegisterClass *SparcRegisterInfo::getPointerRegClass(MachineFunction &MF, unsigned Kind) {
  return Subtarget.is64Bit() ? &SP::I64RegsRegClass : &SP::IntRegsRegClass;
}

```

(c) Code Generation

Figure 5: Examples of three tasks in ComBack.

3.3 Tasks in ComBack

For two common scenarios in compiler backend development, we’ve outlined three tasks, depicted in Fig. 5. For on-the-fly programming, we’ve devised Statement-Level Completion (Fig. 5(a)) and Next-Statement Suggestion (Fig. 5(b)) [37], aiming to speed up the programming process. For situations where programmers provide function descriptions in natural language, we’ve introduced Code Generation (Fig. 5(c)), facilitating direct code generation for a given function. Data processing steps for each task are detailed in subsequent subsections.

Language models fine-tuned with ComBack aid programmers in backend development by completing current statements (Statement-Level Completion), predicting next statements (Next-Statement Suggestion) based on the contextual information. Additionally, it can generate functions based on provided natural language descriptions and target-specific values (Code Generation), reducing repetitive tasks and enhancing efficiency.

3.3.1 Statement-Level Completion

Following the data extraction method used in the code completion dataset of CodexGlue [34], we initially aimed to extract five consecutive statement sequences randomly from each function in every backend. We retained samples where the proportion of tokens in the sequence relative to the entire function exceeded 30%, aiming to capture more contextual semantics. Assuming each sample contains n statements, we used the first $n - 1$ statements along with 50%-90% of tokens from the n_{th} statement as input. The remaining 10%-50% of tokens from the n_{th} statement served as ground truth, with this ratio chosen randomly. We treated tokens like ";", ":", "{", "}" in C/C++ as statement terminators, as described in Sec. 3.2. We maintained the intermediate representations from Sec. 3.2 in the task’s input and ground truth because target-specific values are sourced from ISA of the target,

making accurate prediction based solely on the code context challenging. Finally, we filtered out data with input lengths exceeding 512 tokens or output lengths exceeding 128 tokens, resulting in a total of 161,124 samples for Statement-Level Completion.

3.3.2 Next-Statement Suggestion

Data processing for Next-Statement Suggestion mirrors that of Statement-Level Completion. We randomly extract five consecutive statement sequences from each function in every backend, retaining samples with over 30% of the function’s tokens. The main distinction is that, for a Next-Statement Suggestion sample with n statements, the preceding $n - 1$ statements serve as input, while the n_{th} statement serves as the ground truth, as shown in Fig. 5(b). We also retained the intermediate representation in code and filtered out samples with input lengths exceeding 512 tokens or ground truth lengths surpassing 128 tokens. Finally, we obtained the dataset comprising 216,315 samples for Next-Statement Suggestion.

3.3.3 Code Generation

For Code Generation, we only kept functions with natural language descriptions (68.08% functions in LLVM and 48.12% functions in GCC), discarding those lacking such descriptions. Each function’s description, along with its internal target-specific values, was used as input (typically requiring extraction from ISA manuals), while the entire function (replacing each intermediate representation with corresponding target-specific value) served as the ground truth, as seen in Fig. 5(c). During filtering, samples with input exceeding 256 tokens or ground truth surpassing 512 tokens were removed, retaining 45,296 samples.

4 Experiment

This section addresses the following research questions:

- **RQ.1:** Can ComBack effectively enhance backend development capabilities of various language models? (Sec. 4.2)
- **RQ.2:** Can ComBack facilitate fine-tuning a model to enhance backend development efficiency for new targets of existing types and new types? (Sec. 4.3)
- **RQ.3:** Can ComBack support iterative expansion to improve backend development efficiency for customized targets? (Sec. 4.4)

4.1 Experimental Setup

Fundamental Models. We selected six open-source language models pre-trained or fine-tuned on C or C++ language: 1) CodeBert (Fine-Tuned with C) [14, 16], 2) GraphCodeBert (Fine-Tuned with C) [23, 15], 3) UniXcoder-base-nine [22], 4) CodeT5-base [50], 5) CodeT5+-220M [49] and 6) NatGen [7]. We chose them for two reasons: 1) these models are representative open-source programming language models, suitable for various tasks in ComBack; 2) their relatively small model size helps reduce computational resources needed for training and deployment. All fine-tuned models and code are available at https://huggingface.co/docz-ict/ComBack_Models.

Baselines. For experiment in Sec. 4.3, we include Fork-Flow method as the baseline of conventional development efficiency. Additionally, we choose ChatGPT-3.5-Turbo and Code-LLaMA-34B-Instruct as baselines for mainstream large language models (LLMs). ChatGPT is the most widely used LLM globally, while Code-LLaMA, an open-source LLM designed specifically for code-related tasks, achieves state-of-the-art performance on many code related benchmarks.

Evaluation Metrics. To evaluate the inference capability of models fine-tuned with ComBack, we use exact match accuracy (EM) and Levenshtein Edit Distance Similarity (ED) [22, 34] for Statement-Level Completion and Next-Statement Suggestion. For Code Generation, we use Levenshtein Edit Distance Similarity and BLEU-4 [38] as evaluation metrics. Exact Match was used for the two code completion tasks because it directly measures the correctness of the generated code, meeting developers’ needs in real-time programming. For Code Generation, we chose BLEU-4 to assess structural similarity between the generated code and the ground truth, the higher the BLEU-4 score,

Table 2: Comparison of accuracy across three tasks of six models fine-tuned by ComBack.

Model	Stmt. Comp.		Next. Sugg.		Code. Gen.		Stmt. Comp.		Next. Sugg.		Code. Gen.	
	EM (%)	ED	EM (%)	ED	BLEU-4	ED	EM (%)	ED	EM (%)	ED	BLEU-4	ED
	Without Fine-Tuning						Fine-Tuned					
CodeBert	0.00	0.97	0.00	1.31	0.00	0.44	53.84	77.44	52.67	70.82	23.54	54.63
GraphCodeBert	0.00	0.35	0.00	0.54	0.00	2.41	43.00	71.89	47.10	61.31	20.73	48.83
UniXcoder	0.07	27.56	15.93	29.11	0.00	31.81	67.84	85.06	58.51	75.31	56.24	73.45
CodeT5	0.65	21.45	7.23	23.50	0.00	13.57	66.47	84.34	58.52	76.03	70.87	80.45
NatGen	0.00	13.52	0.02	15.95	0.01	28.76	67.47	84.83	60.30	76.84	71.73	81.39
CodeT5+	0.02	7.24	0.12	9.87	0.00	12.33	66.93	84.45	59.57	76.41	75.29	82.92

the greater the similarity. We also used edit distance for all tasks to measure the modifications needed to align the generated code with the ground truth, where a higher score indicates fewer required edits and closer alignment to the ground truth.

Training Settings. All models are trained and evaluated on a server with a 64-core Intel Xeon Gold CPU and 8 NVIDIA Tesla V100 GPUs, each with 16GB of memory. We set the fine-tuning objective as: sequence-to-sequence prediction for three tasks. To ensure fairness, all hyperparameters are identical for the six models, detailed in Appendix C.

4.2 Accuracy Improvement across Various Models

To evaluate accuracy improvement of different models across three tasks, we randomly split the backend data from all targets into train/validation/test sets in an 80%:10%:10% ratio, with details on the quantity of data and tokens in each set provided in Appendix D. Subsequently, we fine-tuned and tested six models with the dataset. Table 2 shows the accuracy improvement of six models across three tasks after fine-tuning with ComBack. The models exhibited improvements of 41.64 - 77.21 of ED across three tasks, 42.58%-67.77% in absolute terms of EM for Statement-Level Completion and Next-Statement Suggestion, and 20.73-75.29 of BLEU-4 for Code Generation.

Answer to RQ.1: ComBack can effectively improve backend development capabilities of various language models.

4.3 Efficiency Enhancement for New Targets

In Sec. 4.3.1 and Sec. 4.3.2, we simulate code completion and generation scenarios for new targets of existing types and new types. We select CodeT5+ for experiments in following sections, as it achieves the highest accuracy on average across three tasks (Sec. 4.2).

4.3.1 Targets of Existing Types

We simulate code completion and generation scenarios for new targets of existing types. Therefore, we select RISC-V (CPU), ARC (MPU), and NVPTX (GPU) in GCC and LLVM as test sets. Other CPU, MPU, and GPU targets are split into train and validation sets at an 85%:15% ratio. RI5CY in LLVM is excluded since it’s a customized target based on RISC-V and shares most code with it. Further dataset details are provided in Appendix D.

Next, we fine-tuned CodeT5+ with the dataset including CPU, MPU and GPU. We further compared the accuracy of fine-tuned CodeT5+, mainstream LLMs, and conventional backend development methods (Fork-Flow) for backend development of three targets.

Mainstream LLMs. We evaluated the performance of ChatGPT-3.5-Turbo and Code-LLaMA-34B-Instruct across three tasks for RISC-V, ARC, and NVPTX, as shown in Table 3. Inputs for both LLMs closely matched those in ComBack, with the addition of a unified prompt, detailed in Appendix F.

CodeT5+ consistently outperforms two LLMs across three tasks. Specifically, in Statement-Level Completion, CodeT5+ surpasses 37.10%-40.82% for EM compared with ChatGPT and 49.72%-54.57% compared with Code-LLaMA in absolute terms on three targets in GCC and LLVM. The significant improvement in accuracy indicates that *fine-tuning small LLMs with ComBack exceeded large LLMs significantly*. Therefore, ComBack holds significant importance in enhancing the performance of language models in backend development scenarios.

Table 3: Accuracy of code generated by ChatGPT, Code-LLaMA and CodeT5+ fine-tuned by ComBack for targets of existing types.

Model	Stmt. Comp.						Next. Sugg.						Code. Gen.					
	RISC-V		ARC		NVPTX		RISC-V		ARC		NVPTX		RISC-V		ARC		NVPTX	
	EM (%)	ED	EM (%)	ED	EM (%)	ED	EM (%)	ED	EM (%)	ED	EM (%)	ED	EM (%)	ED	EM (%)	ED	EM (%)	ED
GCC																		
ChatGPT	10.34	38.41	15.35	42.94	12.01	41.47	6.44	12.90	9.75	20.79	7.97	17.79	1.37	24.12	1.67	28.26	1.57	26.97
Code-LLaMA	0.41	19.07	0.85	16.77	0.56	18.22	1.58	13.54	2.66	17.95	2.47	16.59	1.67	27.89	1.71	30.49	1.57	27.65
CodeT5+	51.16	75.32	52.45	74.57	50.56	75.52	49.11	67.84	38.26	59.21	38.33	56.31	32.56	58.67	19.94	50.27	25.47	52.60
LLVM																		
ChatGPT	12.08	41.39	16.77	42.02	14.73	43.72	9.80	21.86	10.81	20.66	11.39	22.82	1.23	25.12	1.30	27.19	1.43	25.45
Code-LLaMA	0.45	17.61	0.61	17.21	0.99	17.23	1.75	15.04	0.42	11.27	2.42	16.25	1.43	27.24	1.61	32.12	1.59	28.08
CodeT5+	62.68	82.02	71.34	85.98	64.45	81.53	48.71	68.95	58.68	74.57	47.81	65.51	50.34	72.98	55.38	74.41	44.33	66.36

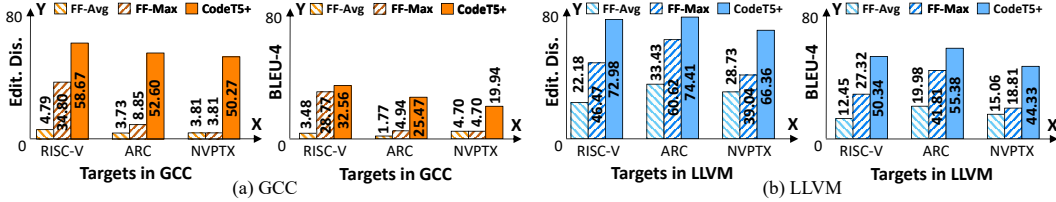

Figure 6: Comparison of fine-tuned CodeT5+ and Fork-Flow for Code Generation, where "FF" is the abbreviation of Fork-Flow.

Fork-Flow. Due to the similarity between the Fork-Flow process, which involves modifying complete functions, and scenarios in Code Generation where developers modify functions automatically generated by the model, we only compare Fork-Flow with fine-tuned CodeT5+ on Code Generation.

To simulate the process of Fork-Flow, we used scripts to calculate the ED and BLEU-4 between functions with identical names on new targets (RISC-V, ARC, NVPTX) and their corresponding implementations on other targets. We aggregate their average and maximum values across these targets (excluding RISC-V, ARC, NVPTX) and compare them with values of functions generated by fine-tuned CodeT5+, as depicted in Fig. 6. It is evident that the accuracy of fine-tuned CodeT5+ exceeds both the average and maximum values of Fork-Flow, demonstrating that the CodeT5+ fine-tuned by ComBack can achieve higher efficiency compared to conventional development method. Details of Fork-Flow can be viewed in Appendix E.

4.3.2 Targets of New Types

We further explore whether ComBack can facilitate code completion and generation for targets of new types. We fine-tune CodeT5+ with CPU data only, excluding MPU and GPU data from train and validation sets in Sec. 4.3.1. Next, we exclude CPU data and only retain MPU and GPU data in the test set, detailed in Appendix D. After fine-tuning CodeT5+ with the dataset only containing CPU, we explore whether it can generate functions for new types of targets (MPU and GPU) in the test dataset.

Results in Table 4 indicate that CodeT5+ fine-tuned on existing types of targets (CPU) can indeed facilitate code completion and generation for new types of targets (MPU and GPU), as backends of different types of targets under the same compiler infrastructure (GCC or LLVM) adhering to unified programming standards (such as same function interfaces and classes).

However, there tends to be a decrease in accuracy on most targets, as depicted in Table 4. Further analysis in Appendix H reveals that there are differences in functions required in the backend of different types of targets. Therefore, the fine-tuned model struggles to effectively complete and generate code corresponding to some functions for new types of targets.

Answer to RQ.2: The model fine-tuned by ComBack can enhance backend development efficiency for new targets of both existing and new types.

4.4 Iterative Expansion Ability

In this section, we explore ComBack's iterative expansion ability. As application scenarios diversify, the field of processor design witnesses a proliferation of customized targets. These targets, often

Table 4: Accuracy across three tasks of targets of new types (MPU and GPU).

Dataset	Stmt. Comp.				Next. Sugg.				Code. Gen.			
	ARC (MPU)		NVPTX (GPU)		ARC (MPU)		NVPTX (GPU)		ARC (MPU)		NVPTX (GPU)	
	EM (%)	ED	EM (%)	ED	EM (%)	ED	EM (%)	ED	BLEU-4	ED	BLEU-4	ED
GCC												
-w/o GPU and MPU	50.53	74.09	46.37	72.45	37.22	58.21	38.33	56.83	19.29	49.12	22.46	50.33
-w GPU and MPU	52.45	74.57	50.56	75.52	38.26	59.21	38.33	56.31	19.94	50.27	25.47	52.60
Diff	-1.92	-0.48	-4.19	-3.07	-1.04	-1.00	0.00	+0.52	-0.65	-1.15	-3.01	-3.37
LLVM												
-w/o GPU and MPU	69.82	85.59	60.04	79.85	58.26	73.75	46.28	63.92	49.62	70.26	42.94	65.43
-w GPU and MPU	71.34	85.98	64.45	81.53	58.68	74.57	47.81	65.5	55.38	74.41	44.33	66.36
Diff	-1.52	-0.39	-4.41	-1.68	-0.42	-0.82	-1.53	-1.58	-5.76	-4.15	-1.39	-0.93

Table 5: Improvement of accuracy across three tasks for RI5CY after iterative expansion.

Dataset	Stmt-Level. Comp.		Next-Stmt. Sugg.		Code. Gen.	
	EM (%)	ED	EM (%)	ED	BLEU-4	ED
-w RISC-V	74.06	87.91	67.25	81.28	79.46	89.92
-w/o RISC-V	66.16	83.79	57.29	74.73	54.41	75.41
Diff	+7.90	+4.12	+9.96	+6.55	+25.05	+14.51

built upon existing targets, integrate customized instructions to swiftly cater to specific application scenarios. Consequently, their backends merely require extensions from the existing backend. We chose RI5CY in LLVM to test if ComBack can be iteratively expanded to improve backend development efficiency for customized targets.

As a target based on RISC-V, RI5CY shares most backend code with RISC-V but includes customized instruction handling. Initially, we fine-tuned CodeT5+ with train and validation set in Sec. 4.3.2 (excluding RISC-V), then we add RISC-V into train and validation set and fine-tuned CodeT5+ with new data (detailed in Appendix D) and restart fine-tuning from scratch. Results in Table 5 show a notable accuracy improvement across three tasks after integrating RISC-V data, demonstrating ComBack’s iterative expansion ability.

Answer to RQ.3: ComBack effectively enables backend development for customized targets by iterative data expansion.

5 Related Work

Backend Development. Compiler backend development heavily relies on manual efforts. Some researchers have proposed Processor Design Languages (PDL) to describe ISA and hardware information for processors [40, 6, 13, 4, 12, 24, 35, 5]. While these methods mitigate manual efforts to some degree, programmers still need to invest significant effort in learning PDL rules and writing files.

Dataset for Compiler. Datasets like CodeXGlue [34] and CodeSearchNet [25] have enhanced language models in programming. As AI extends into compilers, datasets like Compile [21], TenSet [56], and ANGHABENCH [11] focus on compiler optimization. However, there remains a dearth of datasets tailored for compiler backends within the community. ComBack is the first dataset designed to substantially augment the capabilities of language models in backend code generation.

AI for Compilation. AI has driven the widespread adoption of machine-learning-based compilation techniques. These methods have found application in tasks such as developing cost and performance models [54, 44, 55, 42, 36], determining transformation order [48, 17, 39, 29, 8], and optimizing parallel programs [28, 27, 52, 51, 26]. Ongoing projects using transformer models for decompilation [1, 2, 46, 53] and code optimization [10] highlight the significant potential of AI for compilers.

6 Discussion

Limitation. One limitation of ComBack is the absence of function descriptions for highly-customized functions in backends for specific targets. We plan to address this in future iterations of the dataset.

Potential Societal Impact. ComBack does not contain any personally identifiable information or offensive content, thereby mitigating any potential negative societal impact.

Conclusion. In this paper, we introduce ComBack, the first public dataset for compiler backend development. ComBack includes 178 backends for mainstream compilers and features three tasks, including statement-level completion, next-statement suggestion and code generation. It enables efficient backend code completion and generation after fine-tuning language models with ComBack. Our evaluation, conducted on six representative language models, shows that ComBack boosts language models’ performance across all three tasks. Notably, CodeT5+ with only 220M parameters significantly outperforms the efficiency of conventional backend development methods and even surpasses ChatGPT-3.5-Turbo and Code-LLaMA-34B-Instruct across three tasks, suggesting potential improvements in compiler development speed and efficiency.

Acknowledgement

We would like to thank all anonymous reviewers for their insightful feedback. This work was supported by the National Natural Science Foundation of China, Grant No. 62232015. It was also supported by the Major Project of Innovation 2030 – New Generation of Artificial Intelligence, Grant No. 2022ZD0116316.

References

- [1] Jordi Armengol-Estapé and Michael F. P. O’Boyle. Learning c to x86 translation: An experiment in neural compilation, 2021.
- [2] Jordi Armengol-Estapé, Jackson Woodruff, Chris Cummins, and Michael F. P. O’Boyle. SLaDe: A Portable Small Language Model Decompiler for Optimized Assembler. <https://arxiv.org/abs/2305.12520>, 2023.
- [3] BigQuery. Github activity data. <https://console.cloud.google.com/marketplace/details/github/github-repos>, 2024.
- [4] Florian Brandner, Viktor Pavlu, and Andreas Krall. Automatic Generation of Compiler Backends. *Software: Practice and Experience*, 43(2):207–240, 2013.
- [5] Florian Brandner, Viktor Pavlu, and Andreas Krall. Automatic generation of compiler backends. *Software: Practice and Experience*, 43(2):207–240, 2013.
- [6] Gunnar Braun, Achim Nohl, Weihua Sheng, Jianjiang Ceng, Manuel Hohenauer, Hanno Scharwächter, Rainer Leupers, and Heinrich Meyr. A novel approach for flexible and consistent adl-driven asip design. In *Proceedings of the 41st Annual Design Automation Conference, DAC ’04*, page 717–722, New York, NY, USA, 2004. Association for Computing Machinery.
- [7] Saikat Chakraborty, Toufique Ahmed, Yangruibo Ding, Premkumar T. Devanbu, and Baishakhi Ray. Natgen: generative pre-training by “naturalizing” source code. In *Proceedings of the 30th ACM Joint European Software Engineering Conference and Symposium on the Foundations of Software Engineering, ESEC/FSE 2022*, page 18–30, New York, NY, USA, 2022. Association for Computing Machinery.
- [8] Junjie Chen, Ningxin Xu, Peiqi Chen, and Hongyu Zhang. Efficient compiler autotuning via bayesian optimization. In *2021 IEEE/ACM 43rd International Conference on Software Engineering (ICSE)*, pages 1198–1209, Madrid, ES, 2021. IEEE Computer Society.
- [9] CodeParrot. Github code dataset. <https://huggingface.co/datasets/codeparrot/github-code>, 2024.
- [10] Chris Cummins, Volker Seeker, Dejan Grubisic, Mostafa Elhoushi, Youwei Liang, Baptiste Roziere, Jonas Gehring, Fabian Gloeckle, Kim Hazelwood, Gabriel Synnaeve, and Hugh Leather. Large Language Models for Compiler Optimization. <https://arxiv.org/abs/2309.07062>, 2023.

- [11] Anderson Faustino da Silva, Bruno Conde Kind, José Wesley de Souza Magalhães, Jerônimo Nunes Rocha, Breno Campos Ferreira Guimarães, and Fernando Magno Quintão Pereira. Anghabench: a suite with one million compilable c benchmarks for code-size reduction. In *2021 IEEE/ACM International Symposium on Code Generation and Optimization (CGO)*, CGO '21, page 378–390, 2021.
- [12] J. D’Errico and Wei Qin. Constructing portable compiled instruction-set simulators-an adl-driven approach. In *Proceedings of the Design Automation & Test in Europe Conference*, volume 1, pages 1–6, Munich, Germany, 2006. IEEE Computer Society.
- [13] Stefan Farfeleder, Andreas Krall, Edwin Steiner, and Florian Brandner. Effective Compiler Generation by Architecture Description. In *Proceedings of the 2006 ACM SIGPLAN/SIGBED Conference on Language, Compilers, and Tool Support for Embedded Systems*, pages 145—152. Association for Computing Machinery, 2006.
- [14] Zhangyin Feng, Daya Guo, Duyu Tang, Nan Duan, Xiaocheng Feng, Ming Gong, Linjun Shou, Bing Qin, Ting Liu, Daxin Jiang, and Ming Zhou. CodeBERT: A pre-trained model for programming and natural languages. In *Findings of the Association for Computational Linguistics: EMNLP 2020*, pages 1536–1547, Online, November 2020. Association for Computational Linguistics.
- [15] Michael Fu, Van Nguyen, Chakkrit Kla Tantithamthavorn, Trung Le, and Dinh Phung. Vulexplainer: A transformer-based hierarchical distillation for explaining vulnerability types. *IEEE Transactions on Software Engineering*, 49(10):4550–4565, 2023.
- [16] Michael Fu and Chakkrit Tantithamthavorn. Linevul: A transformer-based line-level vulnerability prediction. In *2022 IEEE/ACM 19th International Conference on Mining Software Repositories (MSR)*, pages 608–620, 2022.
- [17] Grigori Fursin and Olivier Temam. Collective optimization: A practical collaborative approach. *ACM Trans. Archit. Code Optim.*, 7(4), dec 2011.
- [18] GCC. Gnu compiler collection. <https://gcc.gnu.or>, 2023.
- [19] Hong-Na Geng, Fang Lv, Ming Zhong, Hui-Min Cui, Jingling Xue, and Xiao-Bing Feng. Automatic target description file generation. *Journal of Computer Science and Technology*, page 1, 0.
- [20] GNU. Gnu mirror list. <https://www.gnu.org/prep/ftp.html>, 2024.
- [21] Aiden Grossman, Ludger Paehler, Konstantinos Parasyris, Tal Ben-Nun, Jacob Hegna, William Moses, Jose M Monsalve Diaz, Mircea Trofin, and Johannes Doerfert. Compile: A large ir dataset from production sources, 2023.
- [22] Daya Guo, Shuai Lu, Nan Duan, Yanlin Wang, Ming Zhou, and Jian Yin. UniXcoder: Unified cross-modal pre-training for code representation. In *Proceedings of the 60th Annual Meeting of the Association for Computational Linguistics (Volume 1: Long Papers)*, pages 7212–7225, Dublin, Ireland, May 2022. Association for Computational Linguistics.
- [23] Daya Guo, Shuo Ren, Shuai Lu, Zhangyin Feng, Duyu Tang, Shujie Liu, Long Zhou, Nan Duan, Alexey Svyatkovskiy, Shengyu Fu, Michele Tufano, Shao Kun Deng, Colin B. Clement, Dawn Drain, Neel Sundaresan, Jian Yin, Daxin Jiang, and Ming Zhou. Graphcodebert: Pre-training code representations with data flow. In *9th International Conference on Learning Representations, ICLR 2021, Virtual Event, Austria, May 3-7, 2021*, Virtual Event, Austria, 2021. OpenReview.net.
- [24] Ashok Halambi, Peter Grun, Vijay Ganesh, Asheesh Khare, Nikil Dutt, and Alex Nicolau. Expression: A language for architecture exploration through compiler/simulator retargetability. In *Proceedings of the Conference on Design, Automation and Test in Europe*, DATE '99, page 100–es, New York, NY, USA, 1999. Association for Computing Machinery.
- [25] Hamel Husain, Ho-Hsiang Wu, Tiferet Gazit, Miltiadis Allamanis, and Marc Brockschmidt. CodeSearchNet challenge: Evaluating the state of semantic code search. *arXiv preprint arXiv:1909.09436*, 2019.
- [26] Wookeun Jung, Thanh Tuan Dao, and Jaejin Lee. Deepcuts: A deep learning optimization framework for versatile gpu workloads. In *Proceedings of the 42nd ACM SIGPLAN International Conference on Programming Language Design and Implementation, PLDI 2021*, page 190–205, New York, NY, USA, 2021. Association for Computing Machinery.

- [27] Yiping Kang, Johann Hauswald, Cao Gao, Austin Rovinski, Trevor Mudge, Jason Mars, and Lingjia Tang. Neurosurgeon: Collaborative intelligence between the cloud and mobile edge. In *Proceedings of the Twenty-Second International Conference on Architectural Support for Programming Languages and Operating Systems*, ASPLOS '17, page 615–629, New York, NY, USA, 2017. Association for Computing Machinery.
- [28] Benjamin C. Lee and David M. Brooks. Accurate and efficient regression modeling for microarchitectural performance and power prediction. In *Proceedings of the 12th International Conference on Architectural Support for Programming Languages and Operating Systems*, ASPLOS XII, page 185–194, New York, NY, USA, 2006. Association for Computing Machinery.
- [29] Hongzhi Liu, Jie Luo, Ying Li, and Zhonghai Wu. Iterative compilation optimization based on metric learning and collaborative filtering. *ACM Trans. Archit. Code Optim.*, 19(1), dec 2021.
- [30] LLVM. The llvm compiler infrastructure project. <http://llvm.org/>, 2023.
- [31] LLVM. LLVM Reference. <https://llvm.org/doxygen/>, 2023.
- [32] LLVM. Writing an llvm backend. <https://llvm.org/docs/WritingAnLLVMBackend.html>, 2023.
- [33] LLVM. Llvm download page. <https://releases.llvm.org/download.html>, 2024.
- [34] Shuai Lu, Daya Guo, Shuo Ren, Junjie Huang, Alexey Svyatkovskiy, Ambrosio Blanco, Colin B. Clement, Dawn Drain, Daxin Jiang, Duyu Tang, Ge Li, Lidong Zhou, Linjun Shou, Long Zhou, Michele Tufano, Ming Gong, Ming Zhou, Nan Duan, Neel Sundaresan, Shao Kun Deng, Shengyu Fu, and Shujie Liu. Codexglue: A machine learning benchmark dataset for code understanding and generation. *CoRR*, abs/2102.04664, 2021.
- [35] P. Marwedel. The mimola design system: Tools for the design of digital processors. In *21st Design Automation Conference Proceedings*, pages 587–593, Albuquerque, NM, USA, 1984. IEEE Computer Society.
- [36] Charith Mendis, Alex Renda, Saman Amarasinghe, and Michael Carbin. Ithemal: Accurate, portable and fast basic block throughput estimation using deep neural networks. In *36th International Conference on Machine Learning, ICML 2019*, 36th International Conference on Machine Learning, ICML 2019, pages 7908–7918, LA, USA, 2019. International Machine Learning Society (IMLS).
- [37] Son Nguyen, Tien Nguyen, Yi Li, and Shaohua Wang. Combining program analysis and statistical language model for code statement completion. In *2019 34th IEEE/ACM International Conference on Automated Software Engineering (ASE)*, pages 710–721, 2019.
- [38] Kishore Papineni, Salim Roukos, Todd Ward, and Wei-Jing Zhu. Bleu: A method for automatic evaluation of machine translation. In *Proceedings of the 40th Annual Meeting on Association for Computational Linguistics*, ACL '02, page 311–318, USA, 2002. Association for Computational Linguistics.
- [39] Sunghyun Park, Salar Latifi, Yongjun Park, Armand Behroozi, Byungsoo Jeon, and Scott Mahlke. Srtuner: Effective compiler optimization customization by exposing synergistic relations. In *2022 IEEE/ACM International Symposium on Code Generation and Optimization (CGO)*, pages 118–130, Seoul, Korea, 2022. IEEE Computer Society.
- [40] Stefan Pees, Andreas Hoffmann, Vojin Zivojnovic, and Heinrich Meyr. Lisa—machine description language for cycle-accurate models of programmable dsp architectures. In *Proceedings of the 36th Annual ACM/IEEE Design Automation Conference*, DAC '99, page 933–938, New York, NY, USA, 1999. Association for Computing Machinery.
- [41] Colin Raffel, Noam Shazeer, Adam Roberts, Katherine Lee, Sharan Narang, Michael Matena, Yanqi Zhou, Wei Li, and Peter J. Liu. Exploring the limits of transfer learning with a unified text-to-text transformer. *arXiv e-prints*, 2019.
- [42] Martin Rapp, Anuj Pathania, Tulika Mitra, and Jörg Henkel. Neural network-based performance prediction for task migration on s-nuca many-cores. *IEEE Transactions on Computers*, 70(10):1691–1704, 2021.
- [43] Ayushi Rastogi and Nachiappan Nagappan. Forking and the sustainability of the developer community participation – an empirical investigation on outcomes and reasons. In *2016 IEEE 23rd International Conference on Software Analysis, Evolution, and Reengineering (SANER)*, volume 1, pages 102–111, Osaka, Japan, 2016. IEEE Computer Society.

- [44] Fabian Ritter and Sebastian Hack. Pmevo: Portable inference of port mappings for out-of-order processors by evolutionary optimization. In *Proceedings of the 41st ACM SIGPLAN Conference on Programming Language Design and Implementation*, PLDI 2020, page 608–622, New York, NY, USA, 2020. Association for Computing Machinery.
- [45] Baptiste Rozière, Jonas Gehring, Fabian Gloeckle, Sten Sootla, Itai Gat, Xiaoqing Ellen Tan, Yossi Adi, Jingyu Liu, Romain Sauvestre, Tal Remez, Jérémy Rapin, Artyom Kozhevnikov, Ivan Evtimov, Joanna Bitton, Manish Bhatt, Cristian Canton Ferrer, Aaron Grattafiori, Wenhan Xiong, Alexandre Défossez, Jade Copet, Faisal Azhar, Hugo Touvron, Louis Martin, Nicolas Usunier, Thomas Scialom, and Gabriel Synnaeve. Code Llama: Open Foundation Models for Code, 2024.
- [46] Hanzhuo Tan, Qi Luo, Jing Li, and Yuqun Zhang. Llm4decompile: Decompiling binary code with large language models, 2024.
- [47] Tree-Sitter. Tree-sitter introduction. <https://tree-sitter.github.io/tree-sitter>, 2024.
- [48] Jack Turner, Elliot J. Crowley, and Michael F. P. O’Boyle. Neural architecture search as program transformation exploration. In *Proceedings of the 26th ACM International Conference on Architectural Support for Programming Languages and Operating Systems*, ASPLOS ’21, page 915–927, New York, NY, USA, 2021. Association for Computing Machinery.
- [49] Yue Wang, Hung Le, Akhilesh Deepak Gotmare, Nghi D. Q. Bui, Junnan Li, and Steven C. H. Hoi. CodeT5+: Open Code Large Language Models for Code Understanding and Generation, 2023.
- [50] Yue Wang, Weishi Wang, Shafiq Joty, and Steven C.H. Hoi. Codet5: Identifier-aware unified pre-trained encoder-decoder models for code understanding and generation. In *EMNLP*, 2021.
- [51] Zheng Wang, Dominik Grewe, and Michael F. P. O’boyle. Automatic and portable mapping of data parallel programs to opencl for gpu-based heterogeneous systems. *ACM Trans. Archit. Code Optim.*, 11(4), dec 2014.
- [52] Jaeyeon Won, Charith Mendis, Joel S. Emer, and Saman P. Amarasinghe. WACO: learning workload-aware co-optimization of the format and schedule of a sparse tensor program. In Tor M. Aamodt, Natalie D. Enright Jerger, and Michael M. Swift, editors, *Proceedings of the 28th ACM International Conference on Architectural Support for Programming Languages and Operating Systems, Volume 2*, ASPLOS 2023, Vancouver, BC, Canada, March 25-29, 2023, pages 920–934, New York, NY, USA, 2023. ACM.
- [53] Xiangzhe Xu, Zhuo Zhang, Shiwei Feng, Yapeng Ye, Zian Su, Nan Jiang, Siyuan Cheng, Lin Tan, and Xiangyu Zhang. Lmpa: Improving decompilation by synergy of large language model and program analysis, 2023.
- [54] Yi Zhai, Yu Zhang, Shuo Liu, Xiaomeng Chu, Jie Peng, Jianmin Ji, and Yanyong Zhang. Tlp: A deep learning-based cost model for tensor program tuning. In *Proceedings of the 28th ACM International Conference on Architectural Support for Programming Languages and Operating Systems, Volume 2*, ASPLOS 2023, page 833–845, New York, NY, USA, 2023. Association for Computing Machinery.
- [55] Jiepeng Zhang, Jingwei Sun, Wenju Zhou, and Guangzhong Sun. An active learning method for empirical modeling in performance tuning. In *2020 IEEE International Parallel and Distributed Processing Symposium (IPDPS)*, pages 244–253, New Orleans, LA, USA, 2020. IEEE Computer Society.
- [56] Lianmin Zheng, Ruo Chen Liu, Junru Shao, Tianqi Chen, Joseph Gonzalez, Ion Stoica, and Ameer Haj-Ali. Tenset: A large-scale program performance dataset for learned tensor compilers. In J. Vanschoren and S. Yeung, editors, *Proceedings of the Neural Information Processing Systems Track on Datasets and Benchmarks*, volume 1. Curran, 2021.

A Appendix: Target List in ComBack.

In Table 6, we provide all targets in ComBack.

Table 6: Target list in ComBack.

Compiler	ISA	Target
GCC	CPU	aarch64, arm, clipper, crx, csky, d30v, i370, i386, i860, i960, ia64, iq2000, loongarch, mep mips, mmix, moxie, mt, nds32, or1k, pa, powerpcspe, pru, riscv, rs6000, rx, sh, sparc stormy16, vax, bfin, c4x, fr30, gcn, nvptx
		1750a, a29k, alpha, arc, avr, cr16, cris, eco32, epiphany, ft32, h8300, lm32, m32c, m32r m68hc11, m68k, m88k, mcore, microblaze, mn10200, mn10300, msp430, nios2, ns32k pdp10, pdp11, rl78, romp, s390, spu, v850, xtensa, z8k
	Virtual	bpf, mapip, visium, vms
	VLIW	c6x, convex, frv, tilegx, tilepro
	LLVM	CPU
DSP		Blackfin, Hexagon, MDSP, SNES, Teak, Videocore, VideoCore4
GPU		AMDGPU, NVPTX, Nyuzi, PTX, R600
MPU		AAP, AGC, Alpha, ARC, ARCompact, AVR, CellSPU, ECLair, Epiphany, GBZ80, J2 LM32, M680x0, M68k, M88k, MBlaze, MCS51, MOS, MSP430, Nios2, P2, PIC16 TL45, TLCS900, TriCore, WDC65816, XCore, Xtensa, Z80, Z80old
Virtual		BPF, DirectX, HSAIL, JVM, mproc, NPEngine, RV16K, SPIRV, TGSI, TPC, TVM WebAssembly
VLIW		Patmos, rvex, Tile64, TMS320C64X

B Appendix: Target abbreviation occurred during pre-processing.

Table 7: Targets Abbreviation in ComBack.

Target	Abbreviation	Target	Abbreviation	Target	Abbreviation
AMDGPU	SI	ARCompact	ARC	Mandarin	MD
Blackfin	BF	CellSPU	SPU	PowerPC	PPC
DirectX	DXIL	GBZ80	GB	R600	SI
RISCV	RISCV	Sparc	SP	Tile64	T64
Videocore	VC	WDC65816	WDC		

In Table 7, we provide all abbreviations for targets in ComBack. Recording these abbreviations can assist us in accurately extracting target-specific values.

C Appendix: Hyperparameters and Input/Output Sequence Length Settings.

In Table 8, we provide all hyperparameter settings. For CodeBert and GraphCodeBert, the input sequence length is set to 384, with output lengths of 128 for Statement-Level Completion and Next-Statement Suggestion, and 256 for both input and output for Code Generation, given the maximum token length of 512 for both models. For the other four models, the input sequence length is set to 512, with output lengths of 128 for Statement-Level Completion and Next-Statement Suggestion, and 256 for input and 512 for output for Code Generation.

Table 8: Hyperparameter settings.

Hyperparameter	Value	Hyperparameter	Value	Hyperparameter	Value
Training Batch Size	32	Beam Size	4	Learning Rate	5e-5
Evaluation Batch Size	16	Max Optimization Steps	3		

D Appendix: Data Statistics about the Number and Token of Three Tasks.

In Table 9, we provide all detailed data of train, validation and test set of experiments in Sec. 4.2 to Sec. 4.4.

Table 9: Data statistics about the number and token of three tasks.

(a) Data statistics about the number and token of three tasks for Sec. 4.2.

Task	Train	validation	Test
Stmt. Comp.	128,899(11.36M Token)	16,112(1.43M Token)	16,113(1.43M Token)
Next. Sugg.	173,052(15.69M Token)	21,631(1.99M Token)	21,632(1.98M Token)
Code. Gen.	36,236(5.10M Token)	4,530(0.64M Token)	4,530(0.64M Token)

(b) Data statistics about the number and token of three tasks for Sec. 4.3.1.

Task	Train	validation	Test
Stmt. Comp.	114,016(10.20M Token)	20,121(1.81M Token)	6,645(0.58M Token)
Next. Sugg.	152,114(14.10M Token)	26,844(2.49M Token)	9,313(0.83M Token)
Code. Gen.	30,633(4.44M Token)	5,406(0.79M Token)	2,819(0.37M Token)

(c) Data statistics about the number and token of three tasks for Sec. 4.3.2.

Task	Train	validation	Test
Stmt. Comp.	87,018(7.78M Token)	15,357(1.37M Token)	2,764(0.26M Token)
Next. Sugg.	113,684(10.65M Token)	20,063(1.87M Token)	4,029(0.38M Token)
Code. Gen.	21,184(3.14M Token)	3,739(0.55M Token)	1,372(0.18M Token)

(d) Data statistics about the number and token of three tasks for Sec. 4.4 (Excluding RISC-V in train and validation set).

Task	Train	validation	Test
Stmt. Comp.	87,018(7.78M Token)	15,357(1.37M Token)	721(0.04M Token)
Next. Sugg.	113,684(10.65M Token)	20,063(1.87M Token)	1,035(0.06M Token)
Code. Gen.	21,184(3.14M Token)	3,739(0.55M Token)	219(0.02M Token)

(e) Data statistics about the number and token of three tasks for Sec. 4.4 (Including RISC-V in train and validation set).

Task	Train	validation	Test
Stmt. Comp.	90,316(8.06M Token)	15,940(1.42M Token)	721(0.04M Token)
Next. Sugg.	118,175(11.04M Token)	20,856(1.94M Token)	1,035(0.06M Token)
Code. Gen.	22,413(3.30M Token)	3,957(0.58M Token)	219(0.02M Token)

E Appendix : Fork-Flow Detailed Experimental Data.

In Table 10, we provide all detailed data in Fork-Flow experiment.

Table 10: Fork-Flow experimental data.

Compiler	Type	Target	BLEU4	ED	EM	Target	BLEU4	ED	EM
GCC	MPU	z8k	0.32	1.33	0	m68k	1.27	2.84	0
GCC	MPU	a29k	0	0	0	m88k	0	0	0
GCC	MPU	avr	4.27	8.85	0.24	microblaze	1.39	3.53	0
GCC	MPU	lm32	1.89	3.68	0.24	mn10200	0	0	0
GCC	MPU	mc98000	1.4	3.61	0	mn10300	2.73	5.47	0
GCC	MPU	mcp430	0.94	1.89	0	nios2	3.35	7.07	0.48
GCC	MPU	v850	2.32	4.58	0	ns32k	0	0	0
GCC	MPU	xtensa	2.93	6.01	0.24	cris	2.43	6.27	0
GCC	MPU	cr16	1.49	3.86	0	pdp11	1.39	3.75	0
GCC	MPU	ri78	0.9	1.69	0	pdp10	0.02	0.25	0
GCC	MPU	m32c	1.35	4.07	0.24	1750a	0	0	0
GCC	MPU	ft32	2.23	4.14	0	s390	3.53	8.05	0
GCC	MPU	h8300	2.48	5.25	0	romp	0	0	0
GCC	MPU	alpha	3.69	7.5	0.24	spu	1.98	3.78	0
GCC	MPU	epiphany	4.94	7.84	0.24	eco32	1.36	2.74	0
GCC	MPU	m32r	4.31	7.85	0.95				
GCC	CPU	aarch64	12.54	18.21	3.51	sparc	3.68	7.81	0.39
GCC	CPU	arm	4.28	7.97	0.39	mep	0.96	2.27	0.19
GCC	CPU	csky	3.77	7.76	0.19	vax	0.78	2.13	0
GCC	CPU	d30v	0.19	0.49	0	clipper	0	0	0
GCC	CPU	i370	0	0	0	iq2000	1.91	4.03	0.39
GCC	CPU	i386	0.26	0.68	0	crx	0.43	1.82	0
GCC	CPU	i860	0	0	0	moxie	1.05	2.77	0.19
GCC	CPU	i960	0	0	0	mt	1.01	2.81	0
GCC	CPU	ia64	2.16	5.71	0	nds32	1.88	4.24	0.19
GCC	CPU	loongarch	28.77	34.8	8.38	pru	2.15	5.28	0.19
GCC	CPU	mips	22.24	29.99	3.51	rs6000	3.41	7.25	0.19
GCC	CPU	mmix	1.75	4.27	0.19	rx	1.01	2.4	0
GCC	CPU	or1k	2.06	4.69	0.19	sh	2.49	5.71	0
GCC	CPU	pa	2.09	4.47	0	stormy16	0	0	0
GCC	CPU	powerpcspe	0.07	0.36	0				
LLVM	GPU	AMDGPU	18.81	39.04	0.58	PTX	12.39	21.79	0.97
LLVM	GPU	Nyuzi	12.74	21.35	1.94	R600	16.31	32.72	0.39
LLVM	MPU	AVR	28.42	45.24	2.33	CellSPU	11.29	25.76	0
LLVM	MPU	LM32	12.55	18.37	3.1	ECLair	3.94	5.4	1.55
LLVM	MPU	MCS51	28.1	43.36	2.33	Epiphany	0.78	0.78	0.78
LLVM	MPU	MSP430	29.04	46.19	2.33	GBZ80	27.87	45.74	0.78
LLVM	MPU	P2	28.72	42.04	4.65	M680x0	24.2	39.33	4.65
LLVM	MPU	PIC16	12.21	26.22	0	M68k	25.49	42.28	5.43
LLVM	MPU	TriCore	18.83	25.93	6.2	M88k	23.26	41.2	5.43
LLVM	MPU	XCORE	41.8	60.62	5.43	MBLaze	15.84	29.81	0
LLVM	MPU	Xtensa	22.1	41.71	6.98	Nios2	12.89	20.59	2.33
LLVM	MPU	AGC	13.11	22.84	3.88	Z80	24.64	43.71	2.33
LLVM	MPU	TL45	24.63	38.95	5.43	Z80old	21.75	38.27	3.1
LLVM	MPU	TLCS900	20.59	32.4	0	MOS	22.77	42.36	3.1
LLVM	MPU	J2	17.75	35.71	2.33	AAP	30.41	44.91	4.65
LLVM	MPU	Alpha	12.81	25.61	0	WDC65816	13.2	22.6	0
LLVM	MPU	ARCCompact	10.4	21.48	0				
LLVM	CPU	AArch64	27.32	46.47	1.5	ORIK	15.18	26.21	0.43
LLVM	CPU	ARM	23.93	42.38	2.14	PowerPC	21.42	39.99	0.75
LLVM	CPU	ARM64	15.33	27.04	0.75	SHUXI	11.21	19.73	1.71
LLVM	CPU	AZPR	2.92	5.72	0.21	Sparc	18.19	32.98	1.61
LLVM	CPU	CAHP	23.54	33.61	5.03	StackPU2	2.08	2.6	0.11
LLVM	CPU	CJG	11.08	19.17	1.61	SystemZ	21.85	38.97	1.39
LLVM	CPU	Cpu0	16.92	29.97	1.28	TOY	9.45	20.55	0.32
LLVM	CPU	CSKY	25.86	38.25	3.53	UPT	5.65	12.1	0.64
LLVM	CPU	DLX	12.13	24.55	1.39	X86	18.88	35.77	1.39
LLVM	CPU	IA64	4.16	9.52	0	XNCM	7.04	14.61	0.21
LLVM	CPU	Kudeyar	8.89	16.03	0.32	Comet2	3.87	7.21	0.96
LLVM	CPU	Lanai	16.7	30.37	1.28	Dcpu16	9.56	18.43	0
LLVM	CPU	LC2200	15.08	24.3	1.71	F2003f	9.24	16.72	0.54
LLVM	CPU	LC3	8.49	17.79	0.86	SIC	11.87	22.42	1.18
LLVM	CPU	LC3b	3.14	6.47	0.32	TeeRISC	8.39	15.64	0.32
LLVM	CPU	LoongArch	13.6	21.83	2.57	Digital	0.87	1.1	0.21
LLVM	CPU	Mandarin	9.24	16.75	0.54	FISC	12.9	25.27	0.96
LLVM	CPU	MINA32	9.96	19.04	1.07	FPGA	1.07	2.01	0.21
LLVM	CPU	Mips	22.96	40.35	2.25	LEG	8.94	18.63	0.86
LLVM	CPU	MMIX	16.42	25.04	3.75	VE	20.54	34.91	2.57
LLVM	CPU	OpenRISC	4.58	9.06	0.21				

F Appendix: Prompt Example of Input for ChatGPT and Code-LLaMA.

We provide prompt examples of Input for ChatGPT and Code-LLaMA in Fig. 7.

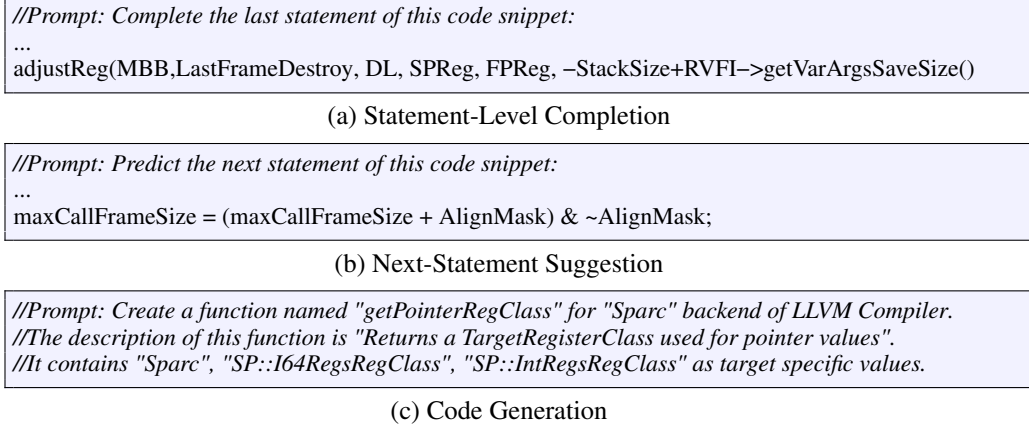

Figure 7: Prompt examples of tasks in ComBack.

G Appendix : License of Assets.

In Table 11, we provide all license of assets in experiment.

Table 11: License of assets.

Assets	CodeBase	License
CodeBER [14]	CodeSearchNet [25]	MIT License
GraphCodeBERT [23]	CodeSearchNet [25]	MIT License
UnixCoder [22]	CodeSearchNet [25], C4 [41]	MIT License
CodeT5 [50]	CodeSearchNet [25], BigQuery1 [3]	Apache-2.0
NatGen [7]	CodeSearchNet [25], BigQuery1 [3]	MIT License
CodeT5+ [49]	GitHub-Code Dataset [9]	bsd-3-clause

H Appendix: Heatmap Analysis.

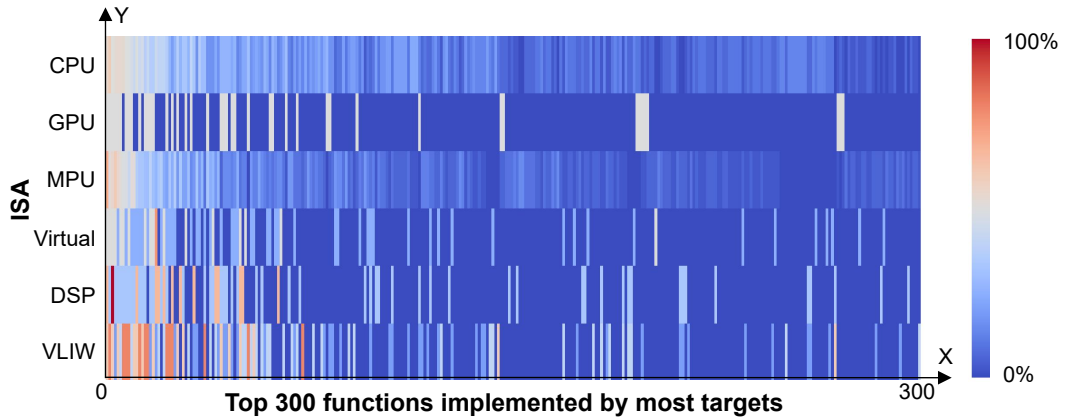

(a) GCC

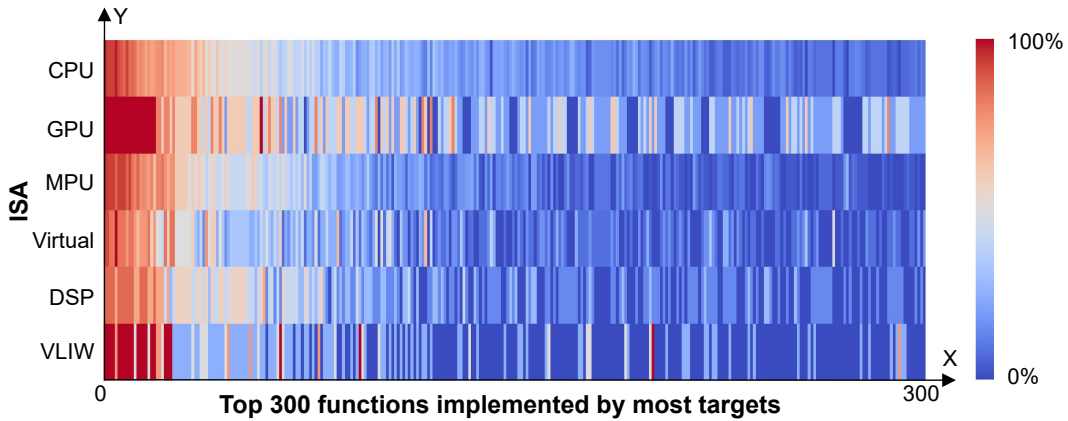

(b) LLVM

Figure 8: Heatmap analysis of top 300 functions implemented by most targets

We analyzed the top 300 functions implemented by most targets in both GCC and LLVM backends, creating Fig. 8 based on target types. CPUs and MPUs showed high similarity, while CPUs and GPUs exhibited significant differences, making it challenging to generate accurate GPU code solely from CPU data. Additionally, VLIW and Virtual targets differed from mainstream CPUs due to variations in instruction sets, highlighting the need to use backend code from similar targets for training, as discussed in Sec. 4.3.1.

Checklist

1. For all authors...
 - (a) Do the main claims made in the abstract and introduction accurately reflect the paper's contributions and scope? [Yes]
 - (b) Did you describe the limitations of your work? [Yes] See Sec. 6
 - (c) Did you discuss any potential negative societal impacts of your work? [Yes] See Sec. 6
 - (d) Have you read the ethics review guidelines and ensured that your paper conforms to them? [Yes]
2. If you are including theoretical results...
 - (a) Did you state the full set of assumptions of all theoretical results? [N/A]
 - (b) Did you include complete proofs of all theoretical results? [N/A]
3. If you ran experiments (e.g. for benchmarks)...
 - (a) Did you include the code, data, and instructions needed to reproduce the main experimental results (either in the supplemental material or as a URL)? [Yes] See **Supplemental Material** and <https://huggingface.co/datasets/docz-ict/ComBack> and https://huggingface.co/docz-ict/ComBack_Models
 - (b) Did you specify all the training details (e.g., data splits, hyperparameters, how they were chosen)? [Yes] See Sec. 4.1
 - (c) Did you report error bars (e.g., with respect to the random seed after running experiments multiple times)? [No]
 - (d) Did you include the total amount of compute and the type of resources used (e.g., type of GPUs, internal cluster, or cloud provider)? [Yes] See Sec. 4.1
4. If you are using existing assets (e.g., code, data, models) or curating/releasing new assets...
 - (a) If your work uses existing assets, did you cite the creators? [Yes] See Sec. 4.1
 - (b) Did you mention the license of the assets? [Yes] See Appendix G
 - (c) Did you include any new assets either in the supplemental material or as a URL? [Yes] See <https://huggingface.co/datasets/docz-ict/ComBack> and https://huggingface.co/docz-ict/ComBack_Models
 - (d) Did you discuss whether and how consent was obtained from people whose data you're using/curating? [N/A]
 - (e) Did you discuss whether the data you are using/curating contains personally identifiable information or offensive content? [Yes] See Sec. 6
5. If you used crowdsourcing or conducted research with human subjects...
 - (a) Did you include the full text of instructions given to participants and screenshots, if applicable? [N/A]
 - (b) Did you describe any potential participant risks, with links to Institutional Review Board (IRB) approvals, if applicable? [N/A]
 - (c) Did you include the estimated hourly wage paid to participants and the total amount spent on participant compensation? [N/A]